



Specification Approval Sheet

Name : Li 7.4V 2200mAh with PCB

Model : 31003

SPEC : 7.4V 18650 2000mAh

Approved By	Checkup	Make

Customer Confirmation	Signature	Date
	Company Name :	
	Stamp :	

436 Kato Terrace, Fremont, CA 94539 U.S.A.

Tel: 510.687.0388 Fax: 510.687-0328

www.TenergyBattery.com



1 Scope

The specification describes the technology parameters and testing standard for the lithium ion rechargeable pack supplied by Tenergy Corporation.

2 Products specified

2.1 Name Cylindrical Lithium Ion Rechargeable Pack

2.2 Type Li 7.4V 18650-2200mAh with PCB

3 References

This specification is referenced GB/T18287-2000、UL1642、IEC61960-1:2000.

4 Caution

4.1 Please read the specification book carefully before testing or using the pack, as improper handling of Lithium-ion pack may result in lose of efficiency, heating ignition, electrolyte leakage or even explosion.

4.2 While testing the pack of charging and discharging, please use the testing equipment special for li-ion pack, forbid to use the ordinary source of constant current and constant voltage, which fails to restrict charge and discharge to pack in order to prevent the pack from being overcharged and over-discharged, triggering losing the function of the pack or dangers.

4.3 When charging and discharging to the pack or packing it into the equipment, reversing the terminals of cathode and anode or it will make the pack overcharging and over-discharging, causing the pack to lose efficiency seriously and even explode.

4.4 Do not weld the pack directly, forbid resolving the pack.

4.5 Do not put the pack together with such metal products as necklace, hairpin, coin or screw in the pocket or in the bag; neither store them together. Forbid to connect the positive and negative electrode directly with such conductive materials as metal, or it may make the pack short-circuit.

4.6 Forbid beating, throwing or trampling the pack, do not put the pack into the washing machine or the high-pressure container.

4.7 Do not get the pack close to heat source, for instance, fire, heater etc. Do not use or deposit the pack under the circumstance of burning sun or the temperature exceeding 60°C, or it may cause the pack to generate heat, heating ignition and lose of efficiency.

4.8 Do not get the pack wet or throw the pack into water, when not in use, it should be put in the dry and low temperature environment.

4.9 While using, testing or preserving the pack, if you find the battery become hot , distribute smell , change color, deform or any other abnormality, please stop using or testing immediately, and attempt to isolate and keep away from the pack.

4.10 If the pack leaks, the electrolyte gets into the eyes, do not rub eyes, instead, rinse the eyes with



clean water, and seek medical service if serious .If the electrolyte gets onto the skin or clothes, wash it with clean water immediately.

5 Basic characteristics

Table 1—Basic characteristics

5.1 Capacity	2200mAh (0.2C ₅ A Discharge)
5.2 Nominal Voltage	7.4V
5.3 Internal impedance	≤ 190mΩ(with PCB)
5.4 Discharge Cut-off Voltage	6.0V
5.5 Max Charge Voltage	8.4±0.02V
6.0 Standard Charge Current	0.2C ₅ A
5.7 Rapid Charge Current	1C ₅ A
5.8 Standard Discharge Current	0.2C ₅ A
5.9 Rapid Discharge Current	1C ₅ A
5.10 Max Discharge Current	2.0 C ₅ A
5.11 Weight	102±3g
5.12 Dimension	length(φ) : 71mm width : 37 mm
	Thickness (H) : 18.5mm
5.13 Operating Temperature	Charge 0 ~ 45°C
	Discharge -20 ~ 60°C
5.14 Storage Temperature	Within 1 month -5 ~ 35°C
	Within 6 months 0 ~ 35°C

6 Capacity Conditions for Test

Unless specified, all tests should be conducted within one month after the delivery under the following conditions: Ambient Temperature:25±5°C; Relative Humidity:65±20%.

Table 2 — Capacity Conditions for Test

6.1 Standard Charge:	Constant Current and Constant Voltage (CC/CV) Current = 440mA Charging to End-up Voltage = 8.4 V Change Constant Voltage to End Current = 22mA
6.2 Standard Discharge:	Constant Current (CC) Current = 440mA End Voltage = 6.0V

7 Appearance

The surface must be clean, no hurt, no rust and with product label.

8 Characteristics

In this section, the Standard Conditions of Tests see the part 6.



8.1 Electrical Performances

Table 3 — Electrical Performances

Item s	Test procedure	Requirements
8.1.1 Nominal Voltage	The average value of the working voltage in the whole discharge progress.	7.4V
8.1.2 Discharge Performance	The discharge capacity of the pack, which is measured at 0.5C5A current discharge to 6.0V within 1 hour after completely charge.	≥114min
8.1.3 Capacity Retention	After 28 days storage at 25±5°C after completed charge, the residual capacity is above 80%.	Capacity≥80%
8.1.4 Cycle Life	After 300 cycles in 100% DOD charge and discharge at 0.5C5A current, the residual discharge capacity is above 60% of nominal capacity.	≥300 cycles
8.1.5 Storage	(Within 3 months after manufactured) after standard charged 40-50% capacity and stored at ambient temperature 25±5°C、65±20%RH for12 months, the storage expiry and the pack completely charged, the pack is discharged at 0.2 C5A current discharge to 6.0V.	Discharge time ≥4h

8.2 Safety Performances

Table 4 — Safety Performances

8.2.1 Short Circuit	The pack is to be short-circuited by connecting the positive and negative terminals of the pack directly with copper wire with a resistance less than 0.1Ω.	No fire, no explosion.
8.2.2 Impact Test	Impacting of a pack on a hard surface following a hammer of 10 kilograms free fall from 1m height.	No fire, no explosion.
8.2.3 Overcharge (3C5A/10V)	The pack that connect with the thermocouple is put in the fume hood, the positive and negative terminals are connected by a permanent constant electrical source, regulate current to 3C5A and voltage to 10 V. Then charge the pack until voltage is 10V, current about 0A. Monitor the temperature change of pack when the temperature of pack is about lower 10°Cthan peak value, the test is over.	No fire, no explosion.
8.2.4 Thermal shock	After standard charging , heat pack to 150±2°Cat rate of 5±2°C/min and keep 10 minutes.	No fire, no explosion.

8.3 Environmental tests

Table 5 — Environmental tests

8.3.1 High temperature performance	The fully charged pack is put in the surroundings of 55±2°C for 2 hours, and then it is discharged to the 6.0V at 1C5A current rate.	Capacity≥80%
------------------------------------	--	--------------



8.3.2 Low temperature performance	The charged pack is put 16-24 hours at $-20\pm 2^{\circ}\text{C}$ and then discharge to 6.0V at 0.2 C ₅ A current rate.	Capacity $\geq 50\%$
8.3.3 Anti-vibration	After standard charging, the pack is fixed on the platform and be subjected to vibrate on following frequency 10~55Hz and amplitude vibration for 30 minutes with direction of X, Y. Vibration Frequency: 10~30Hz, vibration amplitude 0.38mm. Vibration Frequency: 30~55Hz, vibration amplitude 0.19mm	By visual check, the pack is not found to deform, leak, smoke and explode, the pack voltage is no less than 7.2V.
8.3.4 Drop Test	The pack is to be dropped from a height of 1m to hard board in X, Y, Z directions for twice respectively. Then discharge the pack at 1C ₅ A current rate to 6.0V, and undertake more than three circles of standard charge and discharge at 1C ₅ A current rate.	No fire, no explosion.

9 Packing

Keep the packs at the half-fully charged state before packing, Packing box surface must contain following content: name, type, nominal voltage, quantity, weight, date, capacity and impedance.

10 Transportation

Violent shaking, bumping, rain and flaring sun shall be forbidden during the transportation. Keep the packs at the half-fully charged state.

11 Storage

Please keep the pack in the cool and dry environment: Within 1 month $-5 \sim 35^{\circ}\text{C}$ or Within 6 months, $0 \sim 35^{\circ}\text{C}$, Relative humidity $\leq 75\%$, Keep the packs at the half-fully charged state.

11.1 Warranty period of this product is 6 months from leaving plant.

11.2 We will not guarantee against any accidents occurring due to usage against this specification.

11.3 The information in this specification subject to change without prior notice.

11.4 The information contained in this document is for reference only and should not be used as a basis for product guarantee or warranty. For applications other than those described here, please consult your nearest RD Sales Office or Distributors.



12 PCB Specification

The PCB will control each series-wound power system independently.

12.1 Electrical characteristics

Table 6 — Electrical characteristics Top t=25°C

Item	Content	Criterion
Over charge Protection	Over charge detection voltage	4.25±0.05V/cell
	Over charge release voltage	4.05±0.10V/cell
Over discharge protection	Over discharge detection voltage	2.4±0.05V/cell
	Over discharge release voltage	3.0±0.05V/ cell
	Rated operational current	4A
Over current protection	Over current detection current	6-9A
	Release condition	Cut load
	Detection delay time	8.0~16.0ms
Short protection	Detection condition	Exterior short circuit
	Release condition	Cut short circuit
Interior resistance	Main loop electrify resistance	VC=4.2V; RDS≤60mΩ
Current consumption	Current consume in normal operation	4.0μA Type 10.0μA Max
(L*W*H)	30.5*1.5*0.8mm	

12.2 Parts list
Table 7 — BOM

BKD-P2CRD01A BOM

	序号	物料名称	规格/型号	封装	位置/代号	数量	备注
	1	贴片电阻	1K ±5%	0603	R3	1	
贴	2	贴片电阻	330R ±5%	0603	R1, R2	2	
片	3	贴片电容	0.1uF ±20%	0603	C1, C3	2	
料	4	贴片电容	0.01uF ±20%	0603	C2	1	
	5	MOS	AO8822	TSSOP-8	U3, U2	2	
	6	IC	R5460N/K208AA	SOT-23-6	U1	1	
	7	PCB	BKD-P2CRD01A REV:1	30.5*15*0.8mm		1	

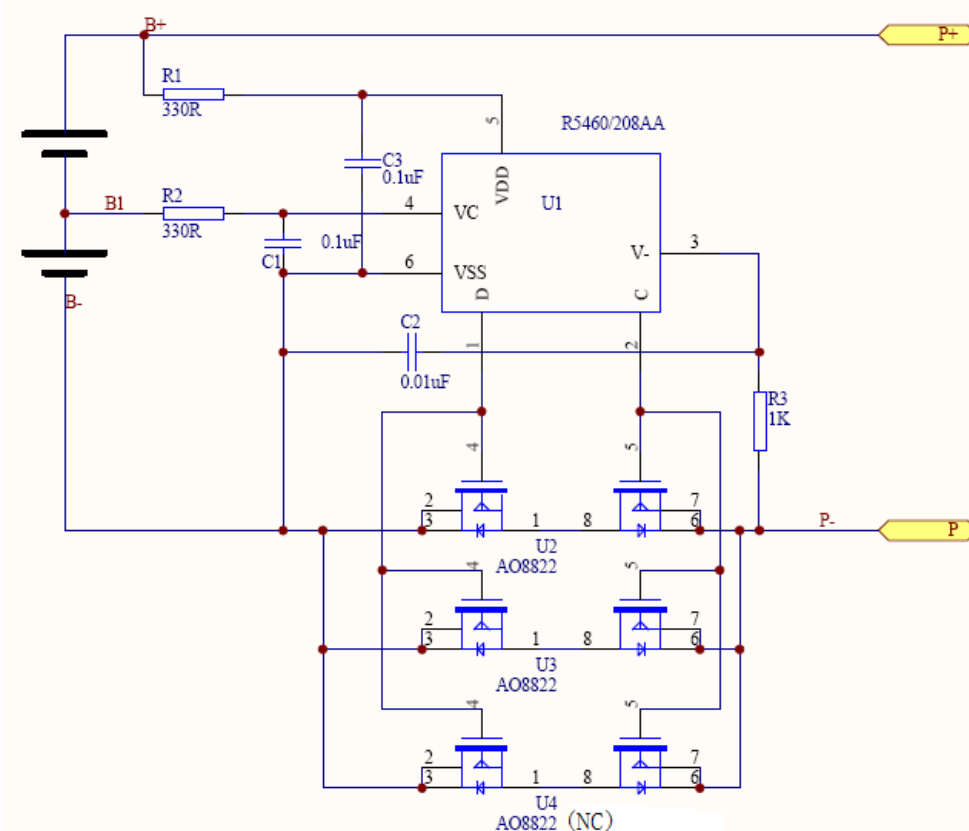
12.3 Application Circuit

12.4 PCB layout

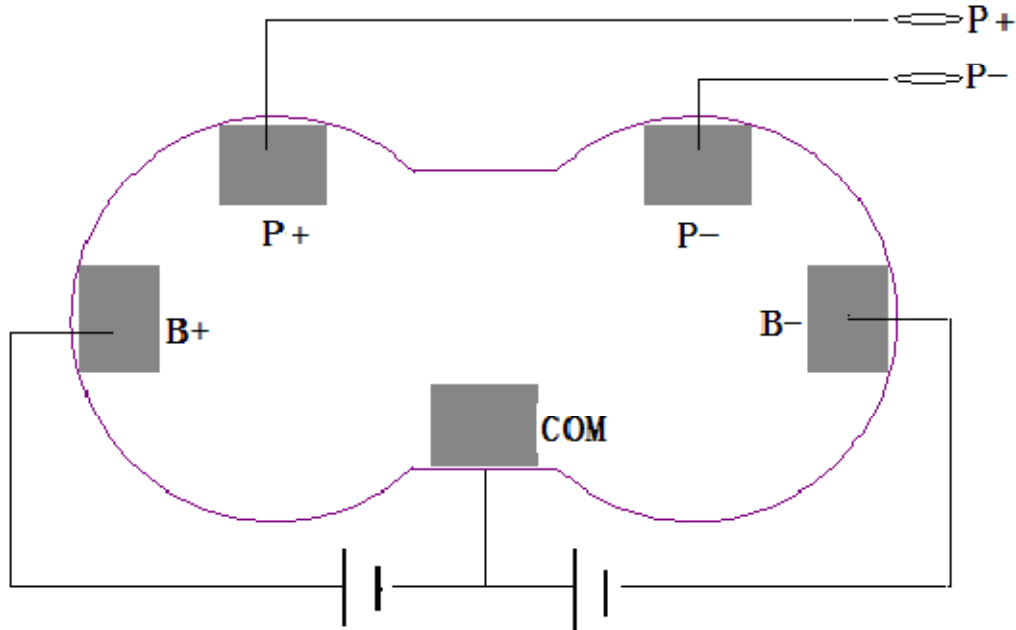

12.5 Terminal explanations

- a) B+: Connected to the second battery's positive terminal
- b) BM/COM: Connected to the first battery's positive terminal
- c) B-: Connected to the first battery's negative terminal
- d) P+: Connected to the battery's output or the charger's positive terminal
- e) P-: Connected to the battery's output or the charger's negative terminal



13 BATTERY PACK DRAWING

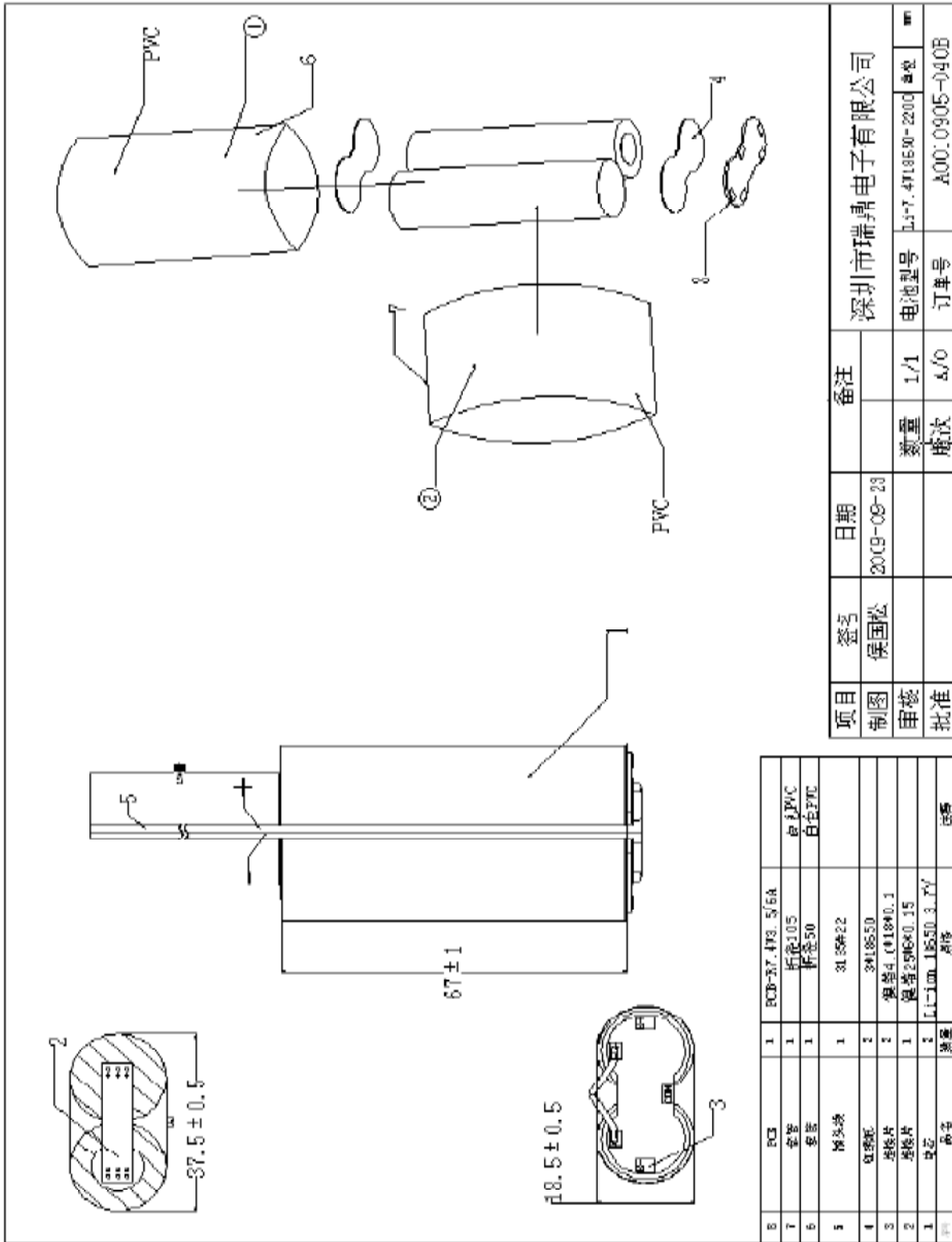

项目	签字	日期	备注
制图	侯国松	2009-09-28	
审核			数量 1/1
批准			版本 4/0
			深圳市瑞鼎电子有限公司
			电池型号 L117-4718530-2200
			订单号 A00:0905-040B