

ENERGIZER NO. L91

AA

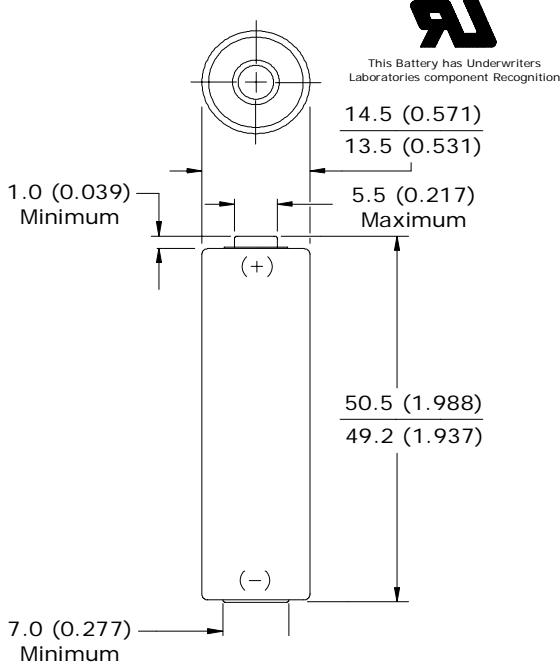

Industry Standard Dimensions in mm (inches)



- Chemical System:** Lithium
Lithium/Iron Disulfide (Li/FeS₂)
- Designation:** ANSI-15LF, IEC-FR6
- Battery Voltage:** 1.5 Volts
- Average Weight:** 14.5 grams (0.5 oz.)
- Typical Volume:** 8.0 cubic centimeters (0.5 cubic inch)
- Storage Temp:** -40°C to 60°C (-40°F to 140°F)
- Operating Temp:** -40°C to 60°C (-40°F to 140°F)
- Average Capacity:** 3000 mAh (to 1.0 volts)
(Rated capacity at 200 mA drain)
- Max Discharge:** 2.0 Amps Continuous
3.0 Amps Pulse, 2 sec on/8 sec off
- Lithium Content:** Less than 1 gram (0.04 oz.) per cell
- Jacket:** Non-magnetic Plastic Label
- Transportation:** Meets requirements of 49CFR 173.185 (b) and IATA special provisions A45
- Shelf Life:** 15 years

CONSTANT CURRENT DISCHARGE
Typical Service

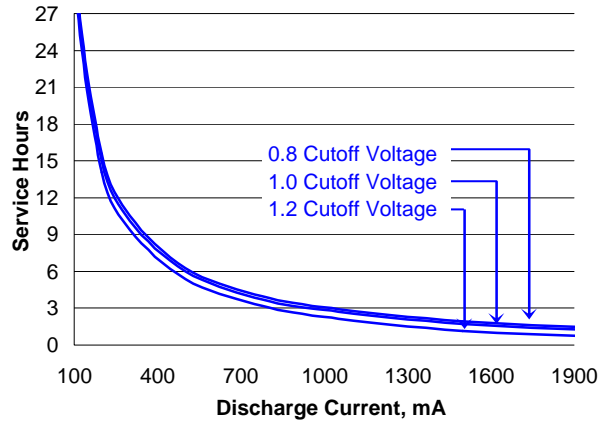

CONSTANT POWER DISCHARGE
Continuous @ 20°C to 0.9 volts

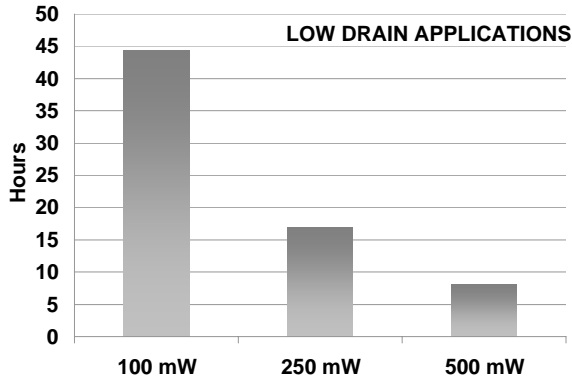

CONSTANT POWER DISCHARGE
Continuous @ 20°C to 1.0 volts

