



<b>Product Name:</b>	NiMH SC 4200	
<b>Product Number:</b>	SCP3600	
<b>Battery Size:</b>	Sub-C	
<b>Battery Chemistry</b>	NiMH	
<b>Dimension:</b>	43mm x 23mm	

**1.BATTERY MODEL**

SCP3600

**2.NOMINAL SPECIFICATION**

2-1.Nominal Voltage	1.2V
2-2.Typical Capacity* <sup>1</sup>	4200mAh
2-3.Minimum Capacity* <sup>1</sup>	3600mAh
2-4.Charging Current* <sup>2</sup>	1800mAh
2-5.Charging Time* <sup>2</sup>	Approx.135 min
2-6.End Voltage of Discharge	1.0V
2-7.Temperature(Recommended)	
Charge:	0~+40deg. C
Discharge:	-20~+50deg. C
Storage: Less than 30 days	-20~+50deg. C
Less than 90 days	-20~+40deg. C
Less than 1 year	-20~+30deg. C
2-8.Humidity	45~85%
2-9.Weight	Approx. 56g

\*1: Discharge capacity when the battery pack is discharged at 720 mA after being charged at 360 mA for 16 hours.

\*2: Use recommended charging systems.



---

### 3.DESIGN,CONSTRUCTION,PHYSICAL DIMENSIONS

The battery unit shall be of the design, construction and physical dimensions shown in the attached drawing.

### 4.APPEARANCE

There shall be no practical damage such as conspicuous liquid electrolyte leakage, flow and dirt under conditions of storage or operation as specified herein.

### 5.ELECTRICAL CHARACTERISTICS

#### 5-1.Full-charge

Full-charge is defined as charged up to fully charged state using a specified fast charger.

The specified fast charger is as follows.

·Charging Current:360mA

·Full charge detection: Peak Voltage

#### 5-2.Terminal voltage(O.C.V)

Open circuit voltage shall be a minimum voltage of 1.30V within 14 days after being fully charged.

#### 5-3.Capacity

##### 5-3-1.

The battery unit shall be capable of supplying 720mA continuous discharge current for a minimum of 280 minutes to 1.0V end voltage within 1 hour after being fully charged.

##### 5-3-2.

The battery unit shall be capable of supplying 1800mA continuous discharge current for a minimum of 108 minutes to 1.0V end voltage within 1 hour after being fully charged.

##### 5-3-3.

The battery unit shall be capable of supplying 3600 mA continuous discharge current for a minimum of 48 minutes to 1.0V end voltage within 1 hour after following process.

The battery unit shall be capable of supplying 30A continuous discharge current for a minimum of 6.3minutes to 1.0V end voltage within 1 hour after following process.

·Charge with 360 mA for 16 hours after discharged with 720 mA to 1.0V.

Remarks: Item 5-3-3.is applied only for the capacity measurement. Please do not use item 5-3-3.for the design of the charger.

#### 5-4. Internal Impedance

After the battery unit is fully charged, within 1~4 hour(s), the internal impedance is not greater than 6mΩ, as tested by 1000Hz AC source.

#### 5-5.Cycle Life

The battery unit shall be capable of 500 minimum cycles under the conditions as follows (The ambient temperature is 18~22 deg. C).

Charge :Paragraph 5-1

Rest :1 hour

Discharge :Paragraph 5-3-2

Rest :1 hour

After 500 cycles, discharge time as specified in paragraph 5-3-2 shall be a minimum of 72 minutes.

#### 5-6.Over-discharge

Fully charged battery unit, when discharged with 7 ohm load for 8 hours, shall not cause damage,



leakage, salting or degradation in performance characteristics as specified herein.

**5-7. Temperature Characteristics**

**5-7-1.**

Within 1 hour after fully charged at 40 deg. C, 0.2C discharge time shall be a minimum of 240 minutes at 20 deg. C as specified in paragraph 5-3-2.

**5-7-2.**

Within 1 hour after fully charged at 20 deg. C, 0.2C discharge time shall be a minimum of 240 minutes at 0 deg. C as specified in paragraph 5-3-2.

**5-8. Self-discharge**

**5-8-1.**

After fully charged unit is stored for 28 days at 20 deg. C, discharge time shall be a minimum of 180 minutes as specified in paragraph 5-3-2.

**5-8-2.**

After fully charged unit is stored for 7 days at 40 deg. C, discharge time shall be a minimum of 240 minutes as specified in paragraph 5-3-2.

**5-9. Safety**

**5-9-1.**

The battery unit shall not explode when it is charged at 1800 mA for 5 hours.

However, it is acceptable for the battery unit to sustain leakage of battery fluid and show a change in appearance.

**5-10. Vibration**

The battery unit shall not sustain damage to its battery performance, when it is tested under the following conditions.

Conditions:	Amplitude	---4mm
	Cycle	---16.7Hz
	Direction	---Three directions(X,Y,Z)
	Time	---60 minutes

**5-11. Supply**

The battery unit shall be shipped at charged state.

**6. Storage**

The battery shall be evaluated within 1 month from the arrival date.

Above mentioned specifications are tested at 18~22 deg. C temperature and 60~70% humidity.

please activate the battery once every 3 months according to the following method:

Charge at 0.1C for 15 hrs, rest 10 min, then discharge with 0.2C to 1.0V/cell, rest 10 min, then charge at 0.2C to 150min.

**Danger!**

- Failure to carefully observe the following procedures and precautions can result in leakage of battery fluid(electrolyte), heat generation, explosion, fire and serious personal injury!
- Never dispose of TENERGY batteries in a fire or heat them.
- Do not connect the (+) positive and (-) negative terminals of TENERGY batteries together with electrically conductive materials, including lead wires. Do not transport or store TENERGY batteries with their uncovered terminals or connected with a metal necklace or other electrically conductive



---

material. When carrying or storing batteries, use a special case.

- Only charge TENERGY batteries using those specific chargers that satisfy Tenergy's specifications. Only charge batteries under the conditions specified by Tenergy.
- Never disassemble TENERGY batteries. Doing so may cause an internal or external short circuit or result in exposed material of battery reacting chemically with the air. It may also cause heat generation, explosion and fire. Also, this is dangerous as it may cause splashing of alkaline fluid.
- Never solder lead wires directly on to TENERGY batteries.
- The (+) positive and (-) negative terminals of TENERGY batteries are predetermined. Do not force the terminals to connect to a charger or equipment. If the terminals can not be easily connected to the charger or the equipment, check if the (+) and (-) terminals are incorrectly positioned.
- The gas release vent which release internal gas is located in the (+) positive terminal of the TENERGY battery. For this reason, never deform his section or cover or obstruct its gas release structure.
- Do not directly connect TENERGY batteries to a direct power source or the cigarette lighter socket in a car.
- Do not use TENERGY batteries in any equipment other than those specified by Tenergy.
- TENERGY batteries contain a strong colorless alkaline solution(electrolyte). The alkaline solution is extremely corrosive and will cause skin damage. If any fluid from a TENERGY battery comes in contact with user's eyes, they should immediately flush their eyes and wash them thoroughly with clean water from the tap or another source and consult a doctor urgently. The strong alkaline solution can damage eyes and lead to permanent loss of eyesight.
- When TENERGY batteries are to be incorporated in equipment or housed within a case, avoid air-tight structures, as this may lead to the equipment or the case being damaged or may be harmful to users.

### **Warning!**

- Do not apply water, seawater or other oxidizing reagents to TENERGY batteries, as this can cause rust and heat generation. If a battery becomes rusted, the gas release vent may no longer operate, and can result in explosion.
- Do not over-charge TENERGY batteries by exceeding the predetermined charging period specified by the battery charger's instructions or indicator. If TENERGY batteries are not fully charged after the battery charger's predetermined charging period has clasped, stop the charging process. Prolonged charging may cause leakage of battery fluid, heat generation, and explosion. Be sure to handle recharged batteries carefully as they may be not.
- TENERGY batteries contain a strong colorless alkaline solution (electrolyte).If the skin or clothing comes in contact with fluid from a TENERGY battery; thoroughly wash the area immediately with clean water from the tap or another source. Battery fluid can irritate the skin.



- 
- Do not connect more than 21 TENERGY batteries in series, as this may cause electrical shocks, leakage of battery fluid and heat generation.
  - Do not remove the outer tube from a battery or damage it. Doing so will expose the battery to the risk of a short circuit, and may cause leakage of battery fluid, heat, generation, explosion and fire.
  - If TENERGY batteries leak fluid, change color, change shape, or change in any other way, do not use them, otherwise they may cause heat generation, explosion and fire.
  - Keep TENERGY batteries and the equipment using them out of the reach of babies and small children, in order to avoid accidental swallowing of the batteries. In the event the batteries are swallowed, consult a doctor immediately.

### **CAUTION!**

- Do not strike or drop TENERGY batteries.
- Store TENERGY batteries out of the reach of babies and small children. When charging or using a battery, do not let babies or small children remove the battery from the charger or the equipment being used.
- Be sure to charge TENERGY batteries within a temperature range of 0 to 40 deg C (degrees Celsius)
- Be sure to use the recommended charging method for TENERGY batteries read the battery charger's instruction manual carefully
- Do not use or store battery at high temperature, such as in strong direct sunlight, in cars during hot weather, or directly in front of a heater. This may cause leakage of battery fluid. It could also impair performance and shorten operating life of TENERGY batteries
- Be sure to turn off the equipment after use of TENERGY batteries, otherwise may result in leakage of battery fluid
- After removed from equipment, store TENERGY batteries in a dry place and within the recommended storage temperature range. This will help preserve the batteries' performance and durability and minimize the possibility of leakage of battery fluid or corrosion.(Tenergy recommends the storage temperature range from -20 to +30deg.(for longer service life).
- To use batteries for the first time after purchase or having not used them for a long period of time, be sure to charge them.
- After long term storage, there is a possibility that the battery could not be fully charged. In order to fully charge it, please charge and discharge battery for a few times.
- Do not use old and new batteries mixed together, or batteries at different charge levels. Do not use the TENERGY battery mixed with a dry cell or other batteries of different capacity, type, or brand name. This may cause leakage of battery fluid and heat generation.



- If the TENERGY battery terminals become dirty, clean up them with a soft dry cloth prior to use. Dirt on the terminals can result in poor contact with the equipment, loss of power, or inability to charge.

**WARRANTY**

Tenergy will be responsible for replacing the batter against any defects or poor workmanship for six months from the date of shipping.

Any other problems caused by malfunction of the equipment or misuse of the battery are not under this warranty.

**SAFETY**

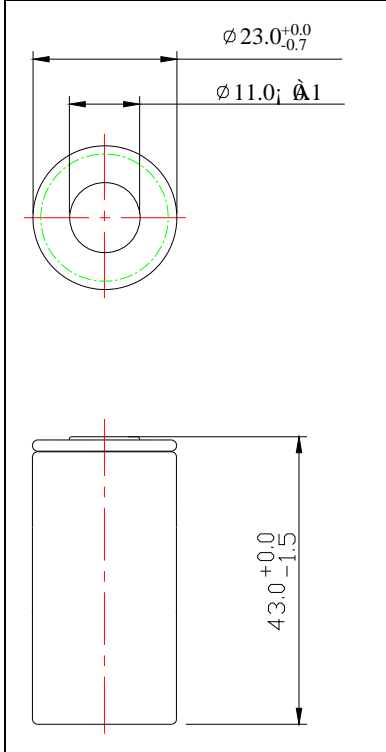
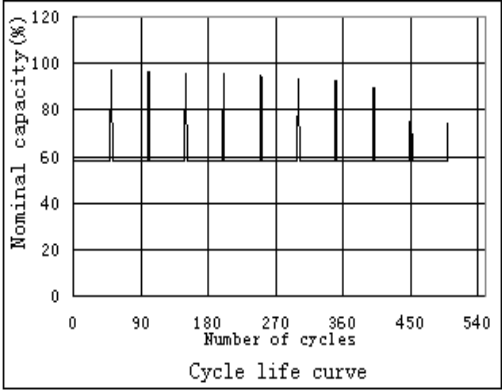
To assure safety, please consult to the Tenergy technical staff for your applications including electrical specifications, mechanical designs, protective devices and any special specification.

TYPE: 43SCP4200			DATA SHEET
<b>Specifications</b>			
Nominal Voltage (V)		1.2	
Capacity *	Typical (mAh)	4200	
	Minimum (mAh)	3600	
Dimension	Diameter (mm)	23.0 <sup>+0</sup> <sub>-0.7</sub>	
	Height(mm)	43.00 <sup>+0</sup> <sub>-1.5</sub>	
Weight	Approx. 56g		
Charging	Standard	360mA(0.1C <sub>5</sub> )×16h	
	Rapid	1800mA(0.5C <sub>5</sub> )×2.4h	
	Trickle	180mA(0.05C <sub>5</sub> )×48h	
Operation Temperature (°C)	Standard Charging	0~45	
	Rapid Charging	10~40	
	Discharging	-20~50	
	Storage	-20~30	
Cut-off Voltage (V)		1.00	

Charging curves at various charging rates

Discharge curves at various discharge rates

Self-discharge (20°C)	≤40%	
<p style="text-align: center;">Dimensions (mm)</p> 		 <p style="text-align: center;">Cycle life curve</p>
		<p><b>Note:</b></p> <p>*: Discharge capacity when the single cell is discharged at 720mA after being charged at 360mA for 16 hours.</p>