

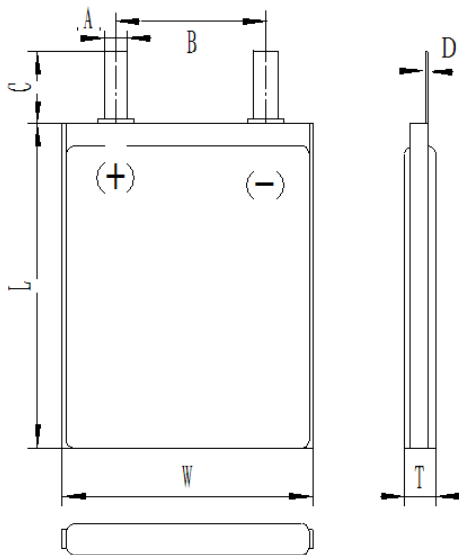

Tenergy Corporation

436 Kato Terrace
 Fremont, CA 94539 U.S.A
 Tel: 510.687.0388 Fax: 510.687.0328
www.TenergyBattery.com email: sales@tenergybattery.com

Product Name:	Li-Polymer 3.7V 4000mAh
Product Number:	30524
Battery Chemistry	Lithium Polymer
Dimension:	135mm x 45mm x 7mm



Sign	Item	Max (mm)	Sign	Item	Max (mm)
A	Tab width	10	T	Cell thickness	6.7
B	Space between Tabs	24	W	Cell width	50.5
C	Tab Length	12	L	Cell length	142.0
D	Tab Thickness	1			



Specifications :

Item		Specifications	Remark
Typital Capacity		<u>4000</u> mAh	25°C, 0.2C ₅ A discharge
Nomimal Voltage		<u>3.7</u> V	25°C, Average Voltage at 0.2C ₅ A discharge
Charge Current	Standard	0.2C ₅ A	Working temperatur : 0~40°C
	Max	1.0C ₅ A	Working temperatur : 0~40°C
Charge cut-off voltage		<u>4.2 ± 0.10</u> V	CC/CV
Continue discharge current		15C <u>60</u> A	
Peak discharge Current		20C <u>80</u> A	Working temperatur : 0~60°C
Discharge cut-off voltage		<u>3.0</u> V	
Impedance		≤ <u>10</u> m Ω	25°C, AC 1KHz after 50% charge
Weight		≤ <u>90</u> g	
Storage temperature	≤1month	-20~45°C	Best 20 ± 5°C for long-time storage
	≤3month	0~30°C	
	≤6month	20 ± 5°C	
Storage humidity		65 ± 20% RH	

General Performance:

Definition of Standard charging method: At 20 ± 5°C, charging the cell initially with constant current 0.2C₅A till voltage 4.2V, then with constant voltage 4.2V till current declines to 0.05C₅A.

Item	Test Methods	Performance
0.2C Capacity	After standard charging, laying the battery 0.5h, then discharging at 0.2C ₅ A to voltage 3.0V, recording the discharging time.	≥300min
15C Discharge	After standard charging, laying the battery 0.5h, then discharging at 5C ₅ A to voltage 3.0V, recording the discharging time.	≥3.3min



Cycle Life	Constant current 1C ₅ A charge to 4.2V, then constant voltage charge to current declines to 0.05C ₅ A, stay 5min, constant current 1C ₅ A discharge to 3.0V, stay 5min. Repeat above steps till continuously discharging time less than 36min.	≥300times
Capability of keeping electricity	20±5°C, After standard charging, laying the battery 28days, discharging at 0.2C ₅ A to voltage 3.0V, recording the discharging time.	≥240min

Environment Performance:

Item	Test Methods	Performance
High temperature	After standard charging, laying the battery 4h at 60°C, then discharging at 0.2C ₅ A to voltage 3.0V, recording the discharging time.	≥270min
Low temperature	After standard charging, laying the battery 4h at -20°C, then discharging at 0.2C ₅ A to voltage 3.0V, recording the discharging time.	≥210min
Constant humidity and temperature	After standard charging, laying the battery 48h at 40±2°C, RH 93±2%. Recording 0.2C ₅ A discharging time	No distortion No electrolytes leakage ≥270 min
Temperature shock	After standard charging, battery stored at -20°C for 2 hours, then stored at 50°C for 2 hours. Repeat 10 times.	No electrolytes leakage



Mechanical Performance:

Item	Test Methods	Performance
Vibration	After standard charging, put battery on the vibration table. 30 min experiment from X,Y,Z axis. Scan rate: 1 oct/min; Frequency 10-30Hz, Swing 0.38mm; Frequency 30-55Hz, Swing 0.19mm.	No influence to batteries' electrical performance and appearance.
Collision	After vibration test, batteries were laying on the vibration table about X, Y, Z axis. Max frequency acceleration: 100m/s^2 ; collision times per minutes: 40~80; frequency keeping time 16ms; all collision times 1000 ± 10 .	No influence to batteries' electrical performance and appearance.
Drop	Random drop the battery from 10m height onto concrete one times.	No explosion or fire

6、 Safety Test:

Test conditions : The following tests must be measured at flowing air and safety protection conditions. All batteries must standard charge and lay 24h.

Item	Test Methods	Performance
Over charge	At $20 \pm 5^\circ\text{C}$, charging batteries with constant current $3C_5A$ to voltage 4.8V, then with constant voltage 4.8V till current decline to 0. Stop test till batteries' temperature 10°C lower than max temperature.	No explosion or fire
Over discharge	At $20 \pm 5^\circ\text{C}$, discharge battery with $0.2C_5A$ continuously 12.5h.	No explosion or fire
Short-circuit	At $20 \pm 5^\circ\text{C}$, connect batteries' anode and cathode by wire which impedance less than $50\text{m}\Omega$, keep 6h.	No explosion or fire
Extrusion	At $20 \pm 5^\circ\text{C}$, put the battery in two parallel steal broad, add pressure 13kN.	No explosion or fire



Thermal shock	Put the battery in the oven. The temperature of the oven is to be raised at $5 \pm 1^{\circ}\text{C}$ per minute to a temperature of $130 \pm 2^{\circ}\text{C}$ and remains 60 minutes.	No explosion or fire
---------------	--	----------------------

Cautions of charge & discharge

Charge

Charging current should be lower than values that recommend below. Higher current and voltage charging may cause damage to cell electrical, mechanical, safety performance and could lead heat generation or leakage.

- (1) Batteries charger should charging with constant current and constant voltage mode;
- (2) Charging current should be lower than (or equal to) $1C_5A$;
- (3) Temperature $0 \sim 45^{\circ}\text{C}$ is preferred when charging;
- (4) Charging voltage must be lower than 4.25V.

Discharge

- (1) Temperature $0 \sim 60^{\circ}\text{C}$ is preferred when discharging;
- (2) Discharging voltage must not be lower than 3.0V.

Over-discharge

It should be noted that the cell would be at an over-discharge state by its self-discharge. In order to prevent over-discharge, the cell shall be charged periodically to keeping voltage between 3.6-3.9V. Over-discharge may cause loss of cell performance. It should be noted that the cell would not discharge till voltage lower than 2.5V.

Storage of polymer lithium-ion batteries

The environment of long-time storage:

Temperature: $20 \pm 5^{\circ}\text{C}$;

Humidity: 45-85%;



Batteries were 40~60% charged.

The battery had better charge a time per three month during its storage for avoiding over discharge. If storage is long time, please charge the battery with constant current $0.5C_5A$ for 1 hour so that it has some storage of charge for properly using.

Charge and discharge afresh to active and renew battery energy after storage above 1 year.

In case of over-discharge, batteries should be charged for one time every 3 months while storing. Batteries should be discharged and charged after being stored more than a year in order to activate it and restore energy.

Transportation of polymer lithium-ion batteries

The batteries should transportation with 10~50% charged states.

Batteries must be properly packed to avoid short circuiting

Others

Short-circuit is strictly prohibited. It should damage batteries badly.

The batteries' tabs are not so stubborn especially for aluminum tabs. Don't bend tabs.

The batteries must be careful of proceed the operation for it's soft package. Please note cautions below to prevent cells' leakage, heat generation and explosion.

Prohibition of disassembly cells;

Prohibition of cells immersion into liquid such as water or seawater;

Prohibition of dumping cells into fire;

Prohibition of using damaged cells. The cells with a smell of electrolyte or leakage must be placed away from fire to avoid firing.

In case of electrolyte leakage contact with skin, eye, physicians shall flush the electrolyte immediately with fresh water and medical advise is to be sought.